



**Met One
Instruments**

50.5 Solid State Wind Sensor

High Quality Sonic Wind Sensors

The 50.5 Solid State Wind Sensor is a continuation of the development work started with NOAA on sonic wind sensors over 25 years ago. This sensor design contains the same wind distortion algorithm and factoring that has been proven and accepted in applications around the world.

No other sensor technology has the history of time proven field performance comparable to the Solid State Series 50.5 Sensor.

FEATURES

- No moving parts
- Digital and analog outputs
- Built-in sensor emulation
- 16-point wind tunnel calibration with each sensor
- Data output is field set to user requirements
- Optional heating unit allows continuous operation in ice and snow
- Low maintenance

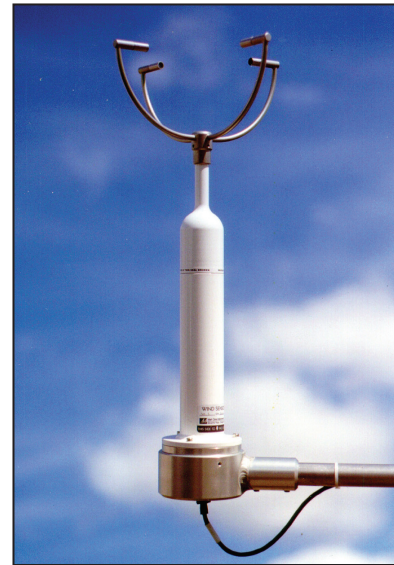

50.5 Solid State Wind Sensor

SPECIFICATIONS

WIND SPEED

Range: 0 - 50 m/sec standard
 Accuracy: ± 0.2 m/sec < 11.3 m/sec or $\pm 2\%$ > 11.3 m/sec
 Resolution: 0.1 m/sec

WIND DIRECTION

Range: 0° - 360°
 Accuracy: $\pm 3^\circ$
 Resolution: 1°

OPERATION

Sampling Rate: 5 per second
 Data Output Rate: 1 per second
 Sonic Frequency: 200 kHz

OUTPUT SIGNALS

Wind Speed Voltage: 0 to 1, 2.5 or 5 VDC (*specified at time of purchase*)
 Wind Direction Voltage: 0 to 1, 2.5 or 5 VDC (*specified at time of purchase*)
 RS-232: 1200 to 19.2K Baud (9600 Baud Standard)
 Optional Digital Outputs: SDI-12, RS-422, RS-485 (*specified at time of purchase*)

**Met One
Instruments, Inc.**

1600 Washington Blvd.,
 Grants Pass, OR 97526
 Tel 541.471.7111
 Fax 541.471.7116
 sales@metone.com



Met One
Instruments

50.5 Solid State Wind Sensor

SPECIFICATIONS

POWER REQUIREMENT

Sensor:	9-18 VDC 10 mA at 12 VDC – average power .75 amp pulse for 2 msec. – peak power
External Heater:	15 Volts DC @ 50 watts

ENVIRONMENTAL

Operating Temperature:	-40°C to +55°C (-40°F to +131°F) no ice
Extended Temperature Range:	-50°C to +55°C (-58°F to +131°F) with external heater

PHYSICAL CHARACTERISTICS

Weight:	5.5 lbs (2.5 kg)
Finish:	Anodized aluminum & stainless steel

CABLE & MOUNTING

PN 9574	Cable Assembly; specify length in feet or meters
Mounting:	PN 3188 Mounting & Orientation Fixture

OPTIONS

PN 50.5H	Wind Sensor with External Heater & Control Box
PN 50.5PS	External Heater Power Source (100 to 240 VAC 50/60 Hz) – 15 VDC @ 4 amps

Heater option must be specified at time of purchase.

Specifications are subject to change at any time.

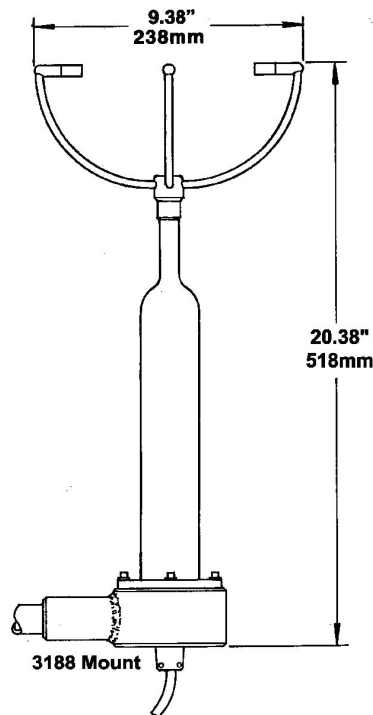

Met One
Instruments, Inc.

1600 Washington Blvd.,
Grants Pass, OR 97526
Tel 541.471.7111
Fax 541.471.7116
sales@metone.com